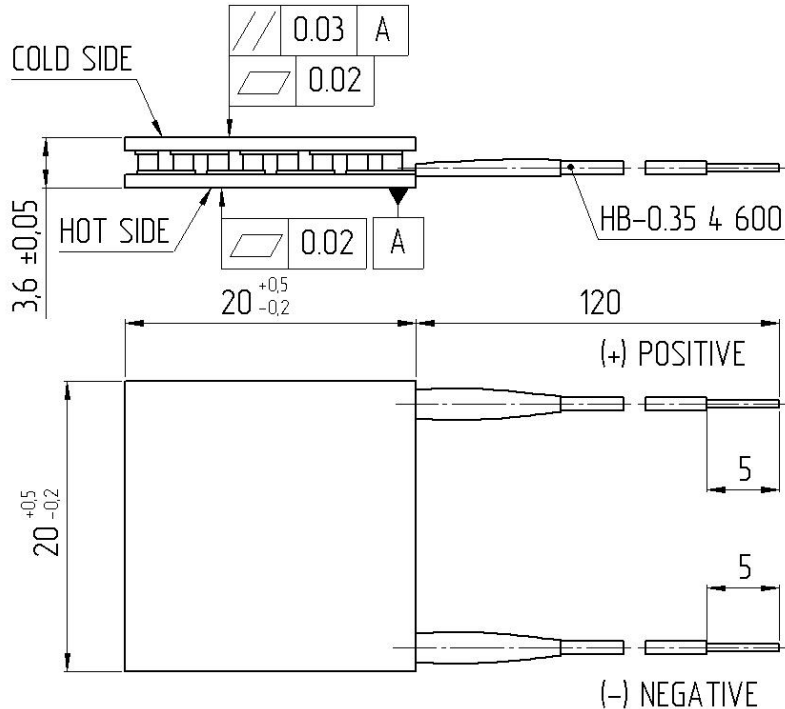
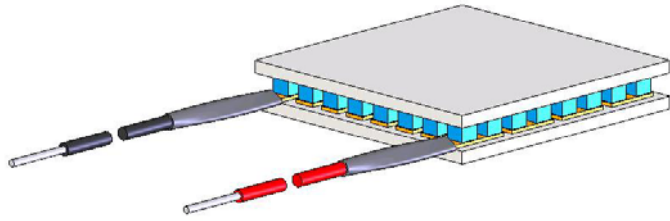

**SPECIFICATION OF THERMOELECTRIC MODULE TB-31-1.4-1.15**

Thermoelectrical parameters	Unit	Value
<b>I<sub>max</sub></b>	Amps	<b>7.9</b>
<b>U<sub>max</sub></b>	Volts	<b>3.8</b>
<b>ΔT<sub>max</sub></b>	K	<b>69</b>
<b>Q<sub>max</sub></b>	Watts	<b>18.6</b>
<b>R<sub>ac</sub> (at 295 K)</b>	Ohm	<b>0.4</b>
<b>Tolerance</b>	%	<b>±10</b>

*All parameters except R<sub>ac</sub> are given at Th=300 K*

Assembly parameters	Unit	Value
<b>Wires</b>		<b>HB-0.35 4 600</b>
<b>Cross section</b>	mm <sup>2</sup>	<b>0.35</b>
<b>Metallization</b>		<b>Not</b>
<b>Sealing</b>		<b>Not</b>
<b>Internal solder</b>	°C	<b>139</b>
<b>Brazing solder</b>	°C	<b>not</b>

Operational parameters	Unit	Value
<b>Working temperature range</b>	°C	<b>-50 ÷ +80</b>
<b>Max. processing temperature</b>	°C	<b>130</b>
<b>ROHS compliance</b>		<b>YES</b>

